

# STEELDECK®

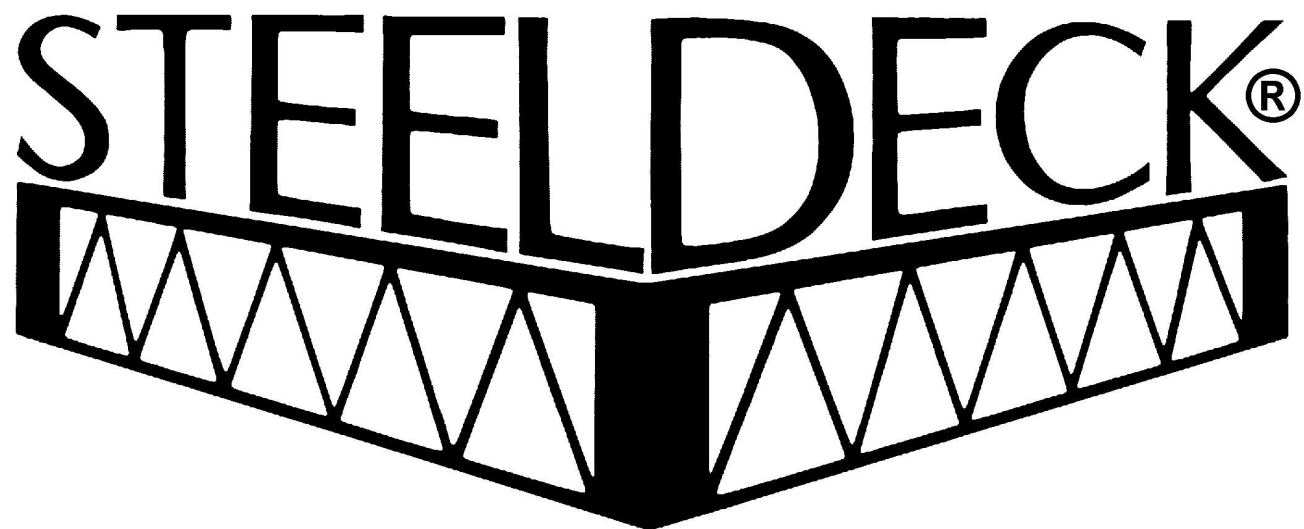

## SETUP & SAFETY INSTRUCTIONS



Our products are subject to continuous development and improvement. Steeldeck® reserves the right to make alterations to the technical data, design or construction of the described products, to stop production of the products or substitute them without prior announcement. All descriptions and technical data in this brochure are for general information only and are not components of a purchasing or a delivery contract. We accept no liability for errors or omissions.

This publication may be freely reproduced, except for advertising, endorsement or commercial purposes.

Steeldeck® is a registered trademark of Steeldeck Industries Ltd.

Steeldeck NY Inc  
141 Banker Street • Brooklyn • New York • 11222  
[www.steeldeckny.com](http://www.steeldeckny.com) • 1-877-60-STAGE

# Steeldeck® Set Up Instructions

## Instructions

For 'How To' Videos, please visit our website <https://steeldeckny.com/how-to-videos/>

Before setting up the decks read these instructions completely. These instructions include:

- A description of the Steeldeck® system
- What loads the decks can take
- How to set up the decks

The person in charge of the team setting up the Steeldeck® platforms should ensure that everyone has had these instructions explained.

## System Description

	<p><b>Steeldeck® platform : Construction Detail</b></p> <p>Steeldeck® platforms consist of a steel truss frame with a socket in each corner and a plywood top. The truss frame is made up from a top chord, a bottom chord, and a distinctive zigzag web. The ¾" birch ply plywood top is screwed to the top chord. The top is backed with flame retardant sound absorbing foam. The socket in the corner takes a scaffolding tube leg which is held in position with a M12 bolt, using a hand knob.</p>
	<p><b>Steeldeck® platform</b></p> <p>Many different sizes and shapes of Steeldeck® platforms can be supplied, proudly manufactured in USA.</p>
	<p>Standard 4'0 x 8'0 units have four holes drilled on the 8'-0" edge and two bolt holes drilled on the 4'-0" edge. (These holes are located on the top chord of the truss and are reinforced on their rear with a square washer.)</p> <p>These holes are to allow neighboring decks to be bolted together. However, not all these are needed in the decks. It is sufficient to only bolt the decks on the periphery together and</p>

then only by a single bolt at each end of the deck. The nuts and bolts are inserted by reaching 10" under the deck. Fit connecting bolts to neighboring units finger-tight as decks are erected. When all the units are erected, tighten connecting bolts. For most activities, due to the stability of the decks, the bolts need only be finger tight. For more vigorous performances the bolts should be tightened with a wrench.

**Note: Bolts should be tightened firmly, not forced.**

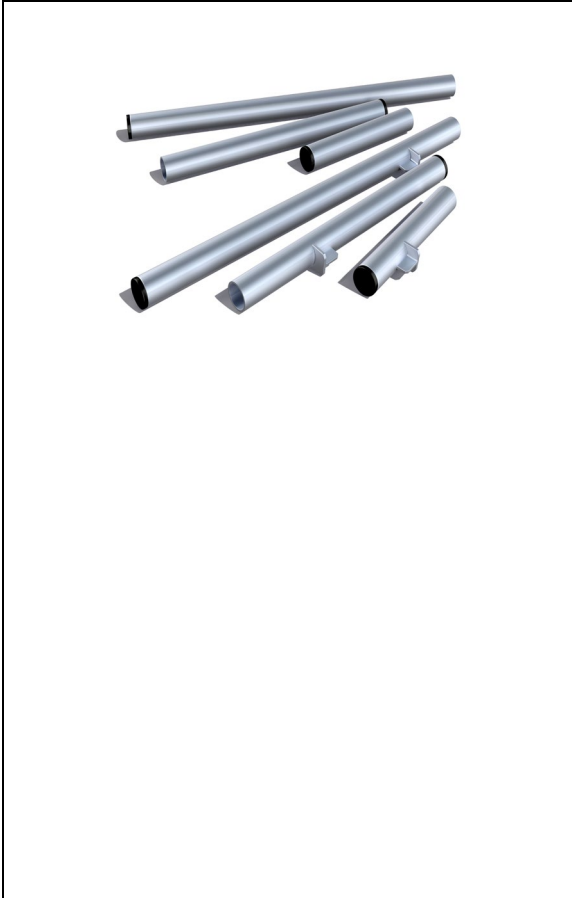

**Legs**  
 Steel scaffolding tube (1 1/2" Sch. 40) legs are used in our patented square corner posts and bolted in. Scaffolding tube is economical, readily available and allows standard scaffolding fittings to be used when bracing a structure. Using different size legs allow the same deck to be set at different heights. Plastic "feet" slot into the bottom of the pipe legs which protect the floor that the deck stands upon.

**Flanged and Hook Legs**  
 Rather than using a coupler, "flanged" legs can be supplied with welded shoulders or hooks to support adjacent decks. Up to four decks can be supported by one leg using one flanged leg.

**To prevent the platform falling and causing possible injury when using flanged legs or couplers, each platform must be securely bolted to the adjacent platform as they are added to the array. It is not necessary for a person to go underneath the array to bolt the platforms together, doing so could cause injury.**



**Raked Stages and Ramps**  
 If a raked stage or ramp is required legs can also be cut and welded at an angle.



**Couplers**  
 Couplers allow up to four adjacent decks to be supported by a single leg. This reduces set up times and allows screwjacks/bracing to be used. The coupler attaches to one leg and enables this one leg to support one, two or three neighboring decks. Up to four decks can be supported by one leg using one coupler.

**To prevent the platform falling and causing possible injury when using flanged legs or couplers, each platform must be securely bolted to the adjacent platform as they are added to the array. It is not necessary for a person to go underneath the array to bolt the platforms together, doing so could cause injury.**

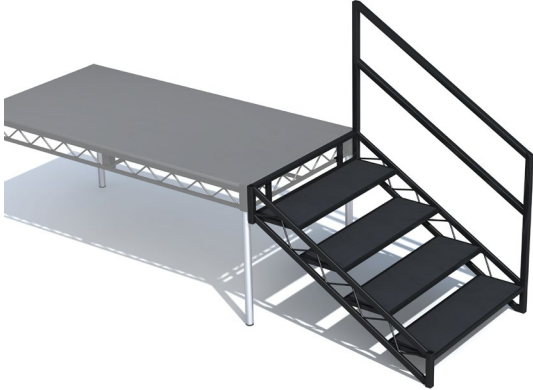
	<p><b>Uneven Ground</b></p> <p>Adjustable baseplates “screwjacks” can be used to level the deck on uneven ground and to spread the load (for example when setting up on a field.)</p> <p>Since screwjacks cannot be set up very close to each other one leg is used to support four adjacent decks using a coupler or a flanged leg (see below).</p>
	<p><b>Rolling Risers</b></p> <p>Casters can be inserted into legs for rolling risers.</p>
	<p><b>Carts</b></p> <p>Casters can be inserted into the deck cornerpost to create a rolling cart for a stack of platforms or other equipment.</p>
	<p><b>Bracing</b></p> <p>For platforms over 4’0 high, bracing is recommended (dependent upon usage).</p> <p>Steel scaffolding (1 ½” Sch. 40) bracing pipe is used with cheeseboroughs (fixed and swivel type).</p>
	<p><b>Bracing Clips “Cheeseboroughs”</b></p> <p>Fixed (90 degree) cheeseboroughs attach chase (horizontal) bracing and swivel cheeseboroughs attach cross (diagonal) bracing.</p>

	<p><b>Steps</b></p> <p>Step units hook onto the bottom cord (<math>\frac{3}{4}</math>" x <math>\frac{3}{4}</math>" ) of the platform truss.</p> <p>Once the platform is installed at the required height, the corresponding height step unit can be installed. At least two people should lift the step into position and hook the unit onto the platform frame.</p> <p>Once in the desired position, tighten the bolts so the unit does not slide.</p> <p>Once the step unit is installed, install the step handrail by sliding the handrail spigot into the open tube of the step stringer.</p>
	<p><b>Guardrails</b></p> <p>Guardrails are attached to the platform using two backplates with hand-knobs.</p> <p>To install guardrails, rest the pins of the guardrail plate on the bottom cord (<math>\frac{3}{4}</math>" x <math>\frac{3}{4}</math>" ) of the platform truss, holding the guardrail in place, to prevent the guardrail falling.</p> <p>Fit the backplate over the pin of the guardrail.</p> <p>Apply the hand-knob through the top hole of the backplate until it catches on the thread of the backplate and tighten. Repeat on the opposite guardrail plate.</p>

## Loads

All Steeldeck® platforms are designed to carry a static (evenly distributed) load of at least 125psf. Some patterns and sizes are able to carry more (up to 250psf). Overloading may cause damage to the decks. Cutting holes in the tops will also weaken the decks.

Before use visually check components for signs of damage e.g., crushed or bent top or bottom chords. Do not use damaged Steeldeck® or decks which have been overloaded. Damaged or overloaded Steeldeck® may have lost their structural integrity and should be immediately removed from use.

## Risk Assessment

Only by considering the unique circumstance of each use of the decks can the risks be assessed and precautions to counter the risks put in place. The risk assessment should consider not only the setting up and the taking down of the Steeldeck® platform but also how the Steeldeck® will be used.

These instructions deal with the setting up and taking down of Steeldeck®. How the Steeldeck® will be used and the precautions which will need to be taken will vary with each individual application.

For example if a stage built from Steeldeck® is to be used by the partially sighted then additional guardrails are likely to be needed.

The risk assessment should consider the risk and precautions to counter them from the manual handling of the decks and falling from any structure built.

## Set up

### **Warnings**

- Decks can be heavy and can injure through poor handling.
- Do not store Steeldeck® where it is exposed to rain or high moisture conditions. Wet conditions or high moisture will cause the steel to corrode and the plywood to rot, reducing the strength of Steeldeck®.
- Platforms built from Steeldeck® may require bracing. Generally platforms up to 5'0 high will not require bracing but if in doubt seek advice.

### **Adding Plain Legs to Individual Deck**

1. Provide two or more people to handle each Steeldeck® unit.
2. Clear set-up area for decks.
3. Stand deck on its long edge.
4. Check that all four legs are fitted with a plastic foot.
5. Insert open end of leg into the bottom corner posts first to prevent tipping and then the legs into the top corner posts.
6. Ensure leg is inserted completely into corner post.
7. Tighten handknob firmly (**do not over-tighten**).
8. Check that all four legs are held securely.
9. Ensure there is enough space to maneuver deck.
10. Stand up deck and place in position.

### **Adding Shared legs/Couplers to Individual Deck**

1. Follow plain leg instructions and install (4) legs into the first platform.
2. If using couplers, bolt them to the plain leg, so the top of the leg fits snugly in the corner post, and the coupler plate is flush with the bottom of the corner post.
3. When installing the four flanged/coupled legs, turn the flanges to accept an adjacent platform either 90 or 45 degrees (dependent upon how many platforms will be shared by the flange or coupler).

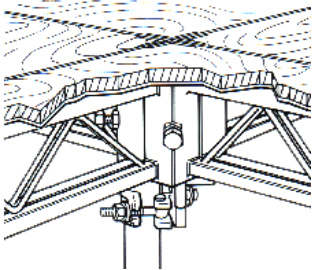

4. Line up the next platform (with no legs on the side which will share legs with the first platform, and legs on the opposite side to continue the leg rhythm) and sit the corner post on the knuckles of the flange or coupler.
5. **The platforms must be bolted together at this point to prevent the platform falling and causing possible injury. Bolt the 2 platforms together by reaching 10" under the deck. It is not necessary for a person to go underneath the array to bolt the platforms together, doing so could cause injury.**
6. Continue building the platform array with the flanged/coupled legs.

### ***Connecting Individual Decks Together***

1. Standard 4'0 x 8'0 units have four holes drilled on the 8'-0" edge and two bolt holes drilled on the 4'-0" edge. (These holes are located on the top chord of the truss and are reinforced on their rear with a square washer.)
2. These holes are to allow neighboring decks to be bolted together. However, not all these are needed in the decks. It is sufficient to only bolt on the decks on the periphery together and then only by a single bolt at each end of the deck. The nuts and bolts are inserted by reaching 10" under the deck.
3. Fit connecting bolts to neighboring units finger-tight as decks are erected.
4. When all the units are erected tighten connecting bolts. For most activities, due to the stability of the decks, the bolts need only be finger tight. For more vigorous performances the bolts should be tightened with a spanner.

### ***Removal to storage***

To breakdown Steeldeck® follow set-up instructions in reverse order.